

PROTECT YOUR EMPLOYEES IN THE NEW NORMAL

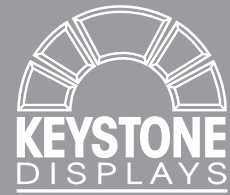

KEEP YOUR OFFICE LAYOUT THE SAME
WITH **HYGIENE BARRIER KITS**



WHETHER YOU HAVE JUST A FEW WORKSPACES OR THOUSANDS,
WE CAN MEET YOUR NEEDS AND **MEET THEM FAST!**
STANDARD AND CUSTOM SOLUTIONS AVAILABLE.

OFFICE HYGIENE BARRIERS SOLUTION KIT

In OSHA's newly published, "Guidance on Preparing Workplaces for COVID-19", the agency specifically suggests, "installing physical barriers, such as clear plastic sneeze guards," as a defense for the spread of COVID-19. We have developed two systems that allow you to maintain your current office layout while keeping people safer. Utilizing minimal framework and clear acrylic, these solutions preserve that feeling of openness while giving extra protection.

TWO STYLES TO CHOOSE FROM

FRAMED



FRAMELESS



TWO CLAMPING SYSTEMS TO FIT PRACTICALLY ANY OFFICE SYSTEM



CUBICLE CLAMP



THIN WALL CLAMP

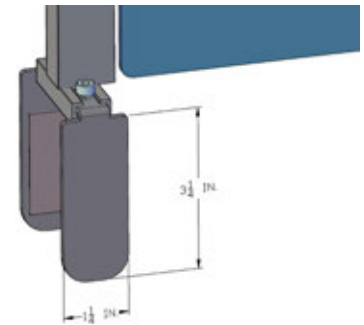

Fits Thicknesses from 2 1/4" to 3 1/2"

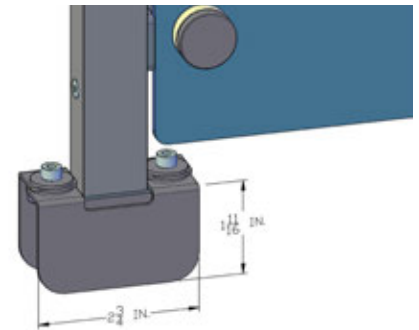

Fits Thicknesses from 3/4" to 2 1/2"

STANDARD SIZES

FRAMED

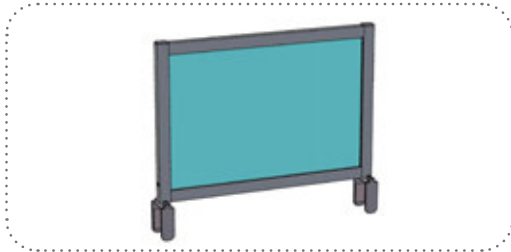

22.5" L x 16" H

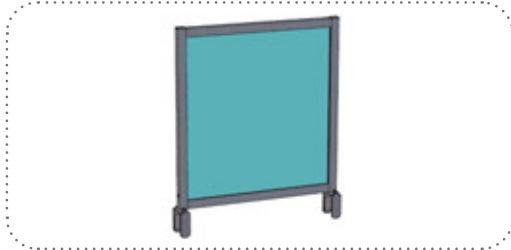

22.5" L x 24" H

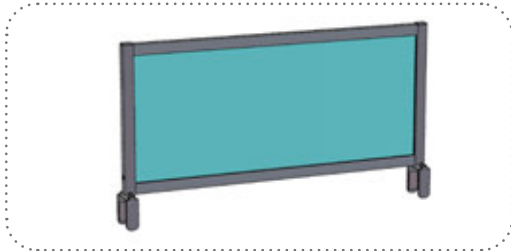

34.5" L x 16" H

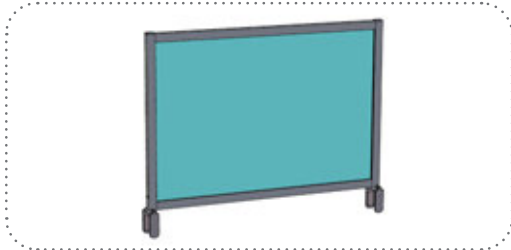

34.5" L x 24" H

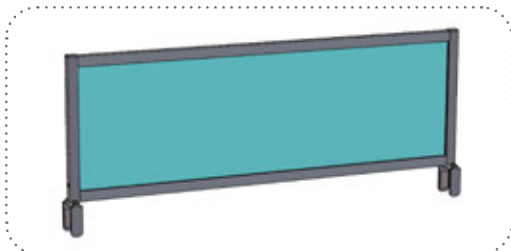

46.5" L x 16" H

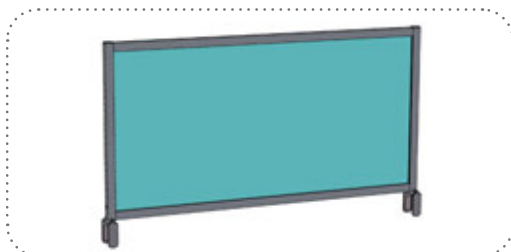

46.5" L x 24" H

FRAMELESS

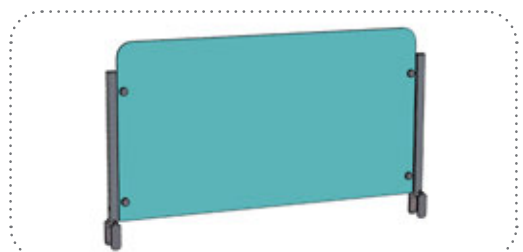
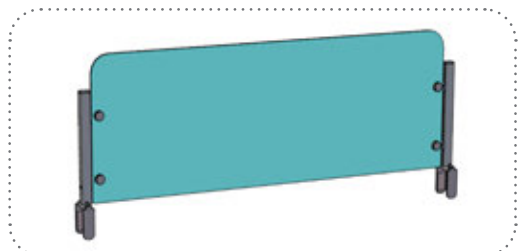
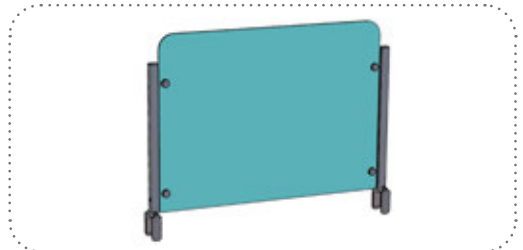
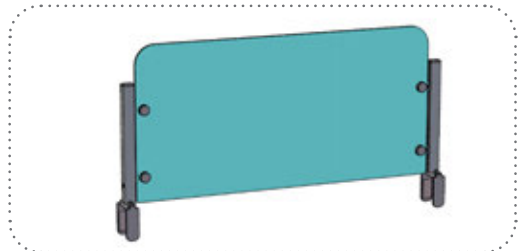
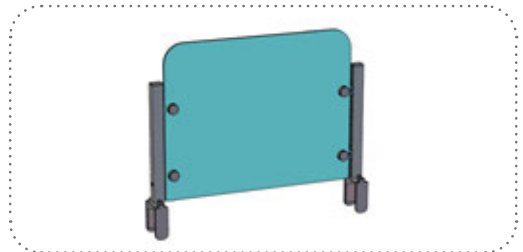

CUSTOM SIZES AVAILABLE

HOW TO BUILD YOUR OWN HYGIENE BARRIER KITS

1. DETERMINE THE STYLE YOU WANT - **FRAMED OR FRAMELESS**
2. PICK YOUR **CLAMP STYLE** BASED ON THE WALL THICKNESS
3. SELECT STANDARD **SIZES** AND ADD CUSTOM SIZES IF NECESSARY
4. DETERMINE **QUANTITIES**
5. **CONTACT US** AT **717-612-0340** FOR QUOTE

DESK AND TABLE APPLICATIONS

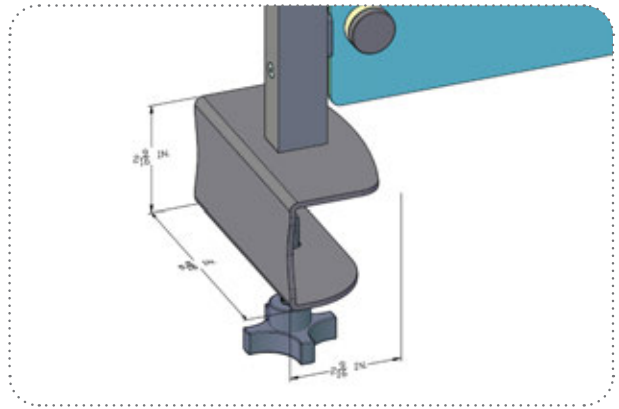
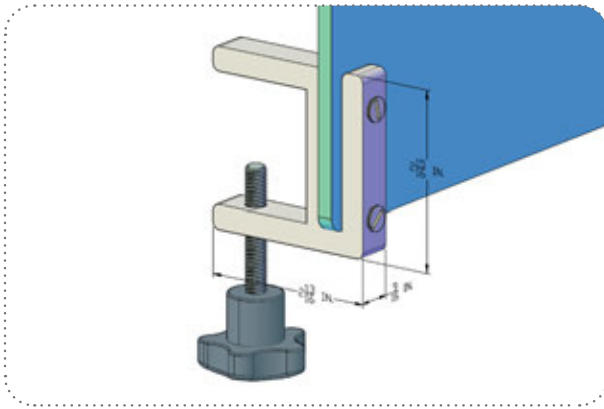

THE PIRANHA
DOOR OPENER



**LESS TOUCH MEANS LESS GERM TRANSMISSION.
ELIMINATE HIGH-TOUCH SURFACE CONTACT ON EVERY DOOR!**

- Made from 11 gauge steel to prevent bending
- High back reduces shoe scuff marks on the door
- Rear plate adds extra strength and support
- Strong powder coated finish
- Carriage bolts lock in position for tightening from one side
- Nuts have nylon inserts to resist loosening

OTHER OFFICE SOLUTION

We can outfit any type of office, whatever the system. And if you need something different than what you've already seen in this catalogue, let us know and we'll help you engineer a custom solution.

BEFORE

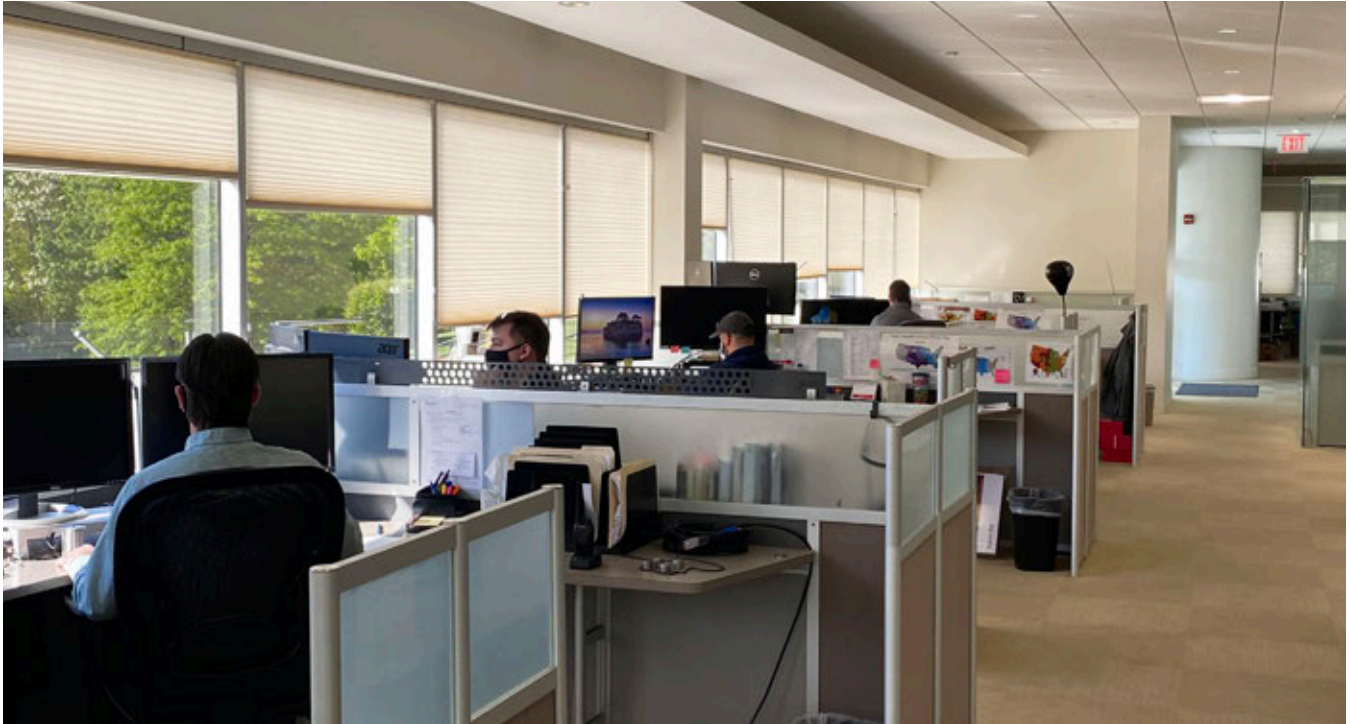

AFTER

